

K4XL's **BAMA**

This manual is provided FREE OF CHARGE from the “BoatAnchor Manual Archive” as a service to the Boatanchor community.

It was uploaded by someone who wanted to help you repair and maintain your equipment.

If you paid anyone other than BAMA for this manual, you paid someone who is making a profit from the free labor of others without asking their permission.

You may pass on copies of this manual to anyone who needs it. But do it without charge.

Thousands of files are available without charge from BAMA. Visit us at <http://bama.sbc.edu>

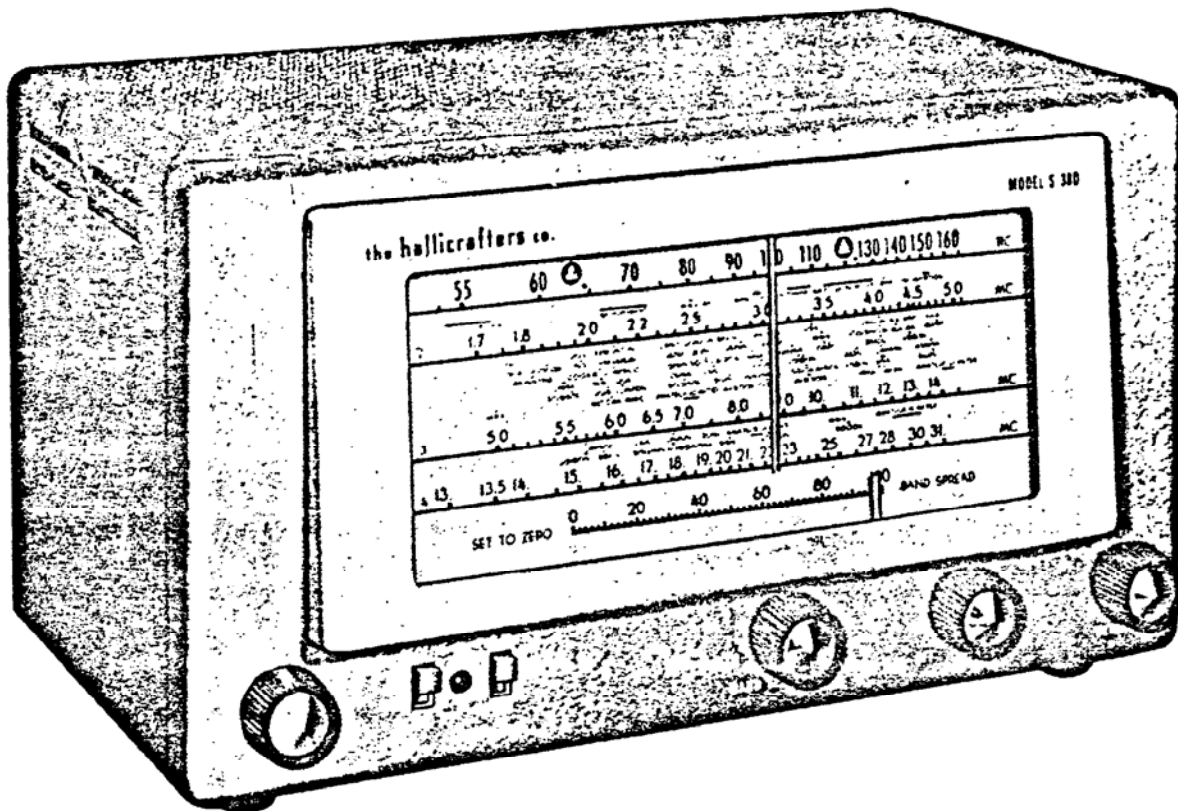

Fig. 1. Hallicrafters Model S-38D

92X2347

GENERAL DESCRIPTION

Your new Hallicrafters Model S-38D tunes from 540 kilocycles to 31 megacycles to bring you the finest in world-wide radio reception. You'll hear foreign and domestic shortwave broadcasts, amateurs, police, aircraft, ships, and countless other exciting distant stations ... as well as all your favorite programs on standard broadcast. The receiver employs 5 tubes in the latest type superheterodyne circuit and provides for the reception of AM (voice) and CW (code) signals over its entire tuning range. It is designed to operate on 105 to 125 volt AC or DC current.

Good reception is usually possible without an outside antenna or ground and, in most localities, satisfactory results can be obtained with just the 15-foot antenna wire included with your receiver.

Special features in your receiver include an electrical bandspread dial for fine tuning of the amateur and shortwave bands, a powerful built-in Alnico V permanent magnet speaker, provisions for headphone operation, and a receive-standby switch on the front panel that permits you to silence the receiver without turning it off.

IMPORTANT

Your careful attention is especially invited to the installation and operating instructions. They have been provided to insure the satisfaction you have a right to expect from a Hallicrafters "Precision Built" product. Your receiver has an unusually high degree of sensitivity necessary to receive weak and distant stations. Careless operation of a high sensitivity receiver may result in excess noise or background hiss. These undesirable effects can be held to a minimum by careful adjustment of the tuning controls as well as the proper selection and arrangement of the antenna.

INSTALLATION

UNPACKING - After unpacking the receiver, examine it closely for damage which may have occurred in transit. Should any sign of damage be apparent, file a claim immediately with the carrier stating the extent of damage. Carefully check all shipping labels and tags for instructions before removing or destroying them.

LOCATION - The receiver is equipped with rubber feet for table or shelf mounting. When locating the receiver, avoid excessively warm locations such as those near radiators and heating vents. Allow at least an inch or two of clearance between the back of the receiver and wall for proper ventilation.

POWER SOURCE - The receiver is designed to operate on 105 to 125 volt AC or DC current. If in doubt about your power source, contact your local power company before plugging in the receiver.

The receiver may also be operated on 210 to 250 volt AC/DC current by using Line Cord Adapter 87D1566, available as an accessory from your Hallicrafters dealer.

HEADPHONES - A twin tip jack, marked "Phones" is provided at the rear of the receiver for connecting headphones or a hearing aid. The headphone output impedance is not critical and any commercial headphones may be used, including crystal types since no direct current flows in the headphone circuit. For maximum headphone output, the use of low-impedance headphones ranging from 50 to 5000 ohms is recommended. For headphone operation, set the Speaker-Phones selector switch at the rear of the receiver at "Phones".

ANTENNAS - The r-f input of the receiver is designed to operate from either a single-wire antenna, or a half-wave doublet or other tuned antenna employing a 52 to 600 ohm transmission line. Antenna connections are made to a three-terminal strip at the rear of the receiver marked "A1", "A2", and "G".

Single-Wire Antenna. The simplest antenna and one which will provide satisfactory performance throughout the entire tuning range is a conventional single-wire antenna. In most localities, satisfactory results can be obtained with just the 15-foot antenna wire included with the receiver. It is simply necessary to attach one end of this wire to terminal "A1", connect the jumper link between "A2" and "G", and then run the wire about the room in any convenient manner. (See Fig. 2.)

If the receiver is operated in a steel constructed building or where receiving conditions are exceptionally poor, an outside antenna 50 to 100 feet long may be necessary. In some locations, reception may be improved by connecting a ground wire (ordinary copper wire) from terminal "G" to a cold water pipe or outside ground rod.

Half-Wave Doublet Antenna. For top performance, especially on the shortwave and amateur bands, the use of a half-wave doublet or other type of antenna employing a 52 to 600 ohm transmission line is recommended. A typical doublet antenna installation is shown in Fig. 3. The doublet antenna should be cut to the proper length for the most used frequency or band of frequencies. The overall length in feet of a doublet antenna is determined by the following formula:

$$\text{Length in feet} = \frac{468}{\text{Frequency in megacycles}}$$

For maximum signal pickup, the doublet antenna should be erected with its length at right angles to the desired station.

The doublet antenna may be fed with either a balanced or unbalanced transmission line. When a balanced transmission line such as "twin-lead" or a twisted pair is used, the transmission line connects to terminals "A1" and "A2", and the jumper link between "A2" and "G" is disconnected. When using an unbalanced transmission line such as coaxial cable, the inner conductor connects to "A1", the outer metal braid connects to "A2", and the jumper link connects between "A2" and "G". A ground wire may improve reception when using an unbalanced type transmission line.

The doublet antenna provides optimum performance only at the frequency for which it is cut. Therefore, it may be desirable for reception on frequencies remote from the antenna frequency to utilize the antenna as a single wire type. This is accomplished by connecting the two transmission line leads together and connecting them to terminal "A1". The jumper link in this case should be connected between terminals "A2" and "G".

In an installation where the receiver is used in conjunction with a transmitter, it may be advantageous to use the same antenna for receiving as for transmitting. This is especially true when a directive antenna is used since the directive effects and power gain of the transmitting antenna are the same for receiving as for transmitting. Switching of the antenna from the transmitter to the receiver may be accomplished with a double-pole, double-throw antenna changeover relay or knife switch connected in the antenna leads.

For further information regarding antennas, refer to the "Radio Amateur's Handbook" or the "A.R.R.L. Antenna Book", both published by the American Radio Relay League, West Hartford, Conn., U.S.A.

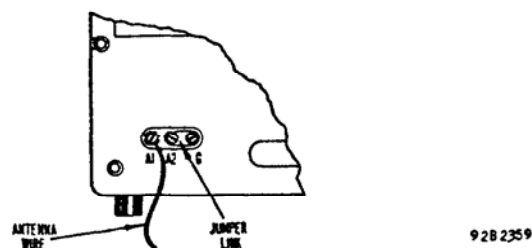

Fig. 2. Single Wire Antenna

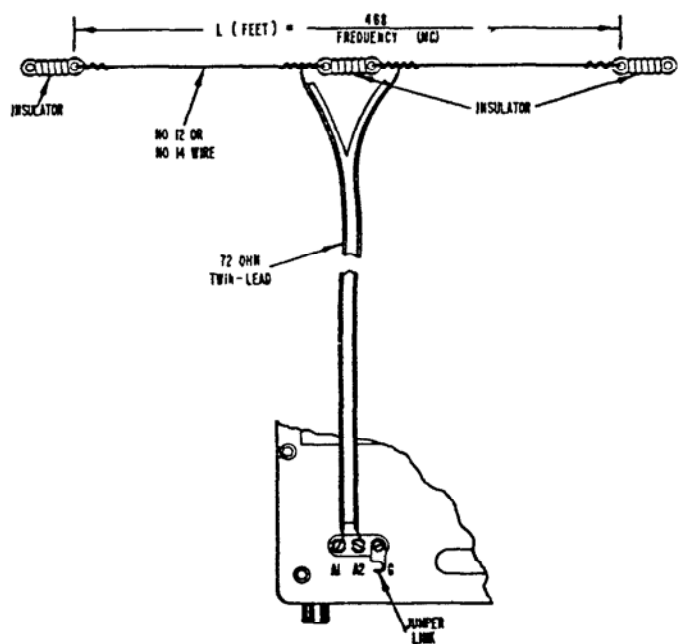

Fig. 3. Doublet Antenna using Twin-Lead Transmission Line

OPERATION

TUNING DIAL - The top dial scale is the standard broadcast band, calibrated in kilocycles minus the last zero. To convert the readings on this band to kilocycles, simply add one zero. For example: 70 on the dial is 700 kilocycles. The shortwave bands are marked 2, 3, and 4. The readings on these bands are in megacycles.

NOTE

The standard broadcast band is marked with a "CD" emblem and a dot at 640 and 1240 kilocycles to indicate the two official civil defense frequencies. In a civil defense emergency, tune to either of these two frequencies for official civil defense news, instructions, and information.

RECEIVE-STANDBY Switch - This switch is normally set at "Receive". When set at "Standby", the receiver is silenced but the tubes remain at operating temperature for instant use. To resume reception at any time, simply return the switch to the "Receive" position.

AM-CW Switch - Set this switch at "AM" to listen to voice or musical broadcasts. Set it at "CW" only if you wish to hear code signals.

BAND SELECTOR Control - Set this control for the band you wish to tune. The four positions of this control correspond to the band numbers at the left side of the dial.

OFF-VOLUME Control - Turn this control clockwise to turn the receiver on and to increase volume. Allow about one minute for the tubes to warm up.

IMPORTANT - When operating on DC (direct current), reverse the power plug in the wall outlet if the receiver does not operate after the one minute warm up. On DC, the receiver will operate ONLY with the plug in one position. When operating on AC (alternating current), try reversing the power plug for minimum hum after the receiver is in operation.

To turn the receiver off, simply rotate the Off-Volume control fully counterclockwise, until a click is heard.

SPEAKER-PHONES Switch - This switch is located at the rear of the receiver. Set it at "Speaker" to operate the built-in speaker or at "Phones" for headphone operation.

TUNING and BANDSPREAD Controls - The Tuning and Bandspeed controls are used in conjunction with one another to tune in the desired signal. Wide tuning is performed with the Tuning control and fine tuning with the Bandspeed control.

To tune the receiver, set the Bandspeed dial pointer at "0" and then slowly turn the Tuning control to the desired station. After the station has been accurately tuned in, reset the Off-Volume control as desired. When trying to locate weak distant stations, it is suggested that the Off-Volume control be initially set near maximum and then readjusted for the desired level after the station has been tuned in. If the signal is too strong, always reduce it by means of the Off-Volume control, not by using the Tuning control. For CW (code) reception, adjust the Tuning control for the desired pitch when tuning in the station.

IMPORTANT: The dial readings will correspond to the station frequencies only if the Bandspeed dial pointer is set at "0".

Fine Tuning with the Bandspeed Control. The Bandspeed control is an electrical fine tuning adjustment for use on all bands. Used in conjunction with the Tuning control, it permits you to accurately tune in stations on crowded bands by spreading them out so they can be more easily separated. The Bandspeed control may be used in two different ways.

The first method of tuning is used when it is desired to tune in a single signal with precision accuracy. The Bandspeed dial pointer is set at about "5", then the signal is located with the Tuning control, and finally the signal is accurately tuned in by "rocking" the Bandspeed control (turning it a few degrees to the left and right) until the signal is loudest and clearest.

The second method of tuning is used when it is desired to tune through a range of frequencies, such as the amateur bands, a group of shortwave stations, etc. Set the Bandspeed dial pointer at "0", set the Tuning control for the high end of the selected band or range of frequencies, and then tune through the range with the Bandspeed control. Turning the Bandspeed control from "0" to "100" tunes the receiver progressively lower in frequency.

Stations of special interest may be accurately logged and relocated by noting the settings of the tuning and bandspeed dial pointers and recording them in the station log provided on the back cover.

SERVICE DATA

TECHNICAL SPECIFICATIONS

TUBES Five including rectifier
 SPEAKER 5-inch PM; 3.2-ohm voice coil
 HEADPHONE OUTPUT 15 ohms
 (See "Headphones", page 3)
 ANTENNA INPUT For single wire or 52-600 ohm
 balanced or unbalanced line
 POWER SOURCE 105-125 volts DC or 50/60 cycles AC
 POWER CONSUMPTION 30 watts
 RECEPTION AM and CW
 INTERMEDIATE FREQUENCY 455 KC
 WEIGHT Net-11 lb., Shipping-13 lb.
 DIMENSIONS 13" x 7 1/2" x 8 7/8" deep

TUBE AND DIAL LAMP REPLACEMENT

The dial lamp and tubes are accessible for replacement by removing the cabinet back. For types used and location, refer to Fig. 7.

CAUTION: Before attempting to make any replacement, rotate the Bandspread control fully clockwise and the Tuning control fully counterclockwise to prevent damage to the tuning gang.

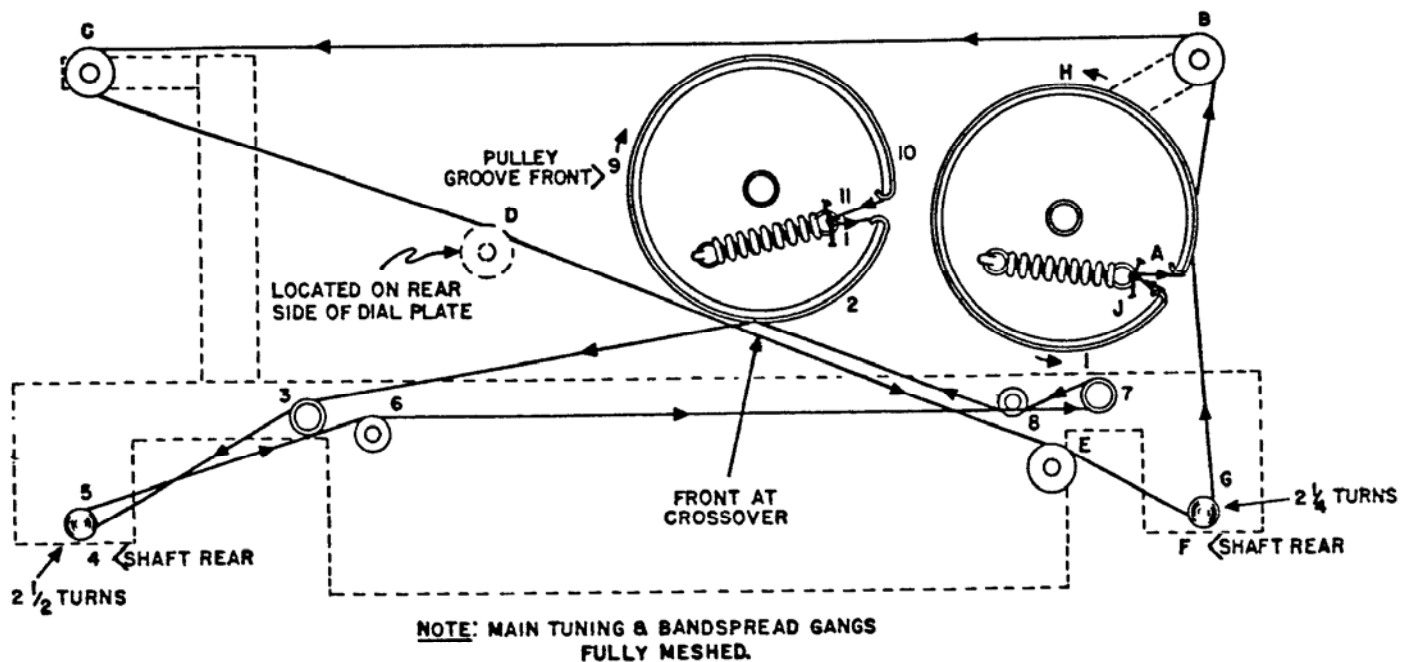

Fig. 4. Main Tuning Pointer Drive and Band Spread Gang and Pointer Drive Stringing Diagrams.

92C1472-A

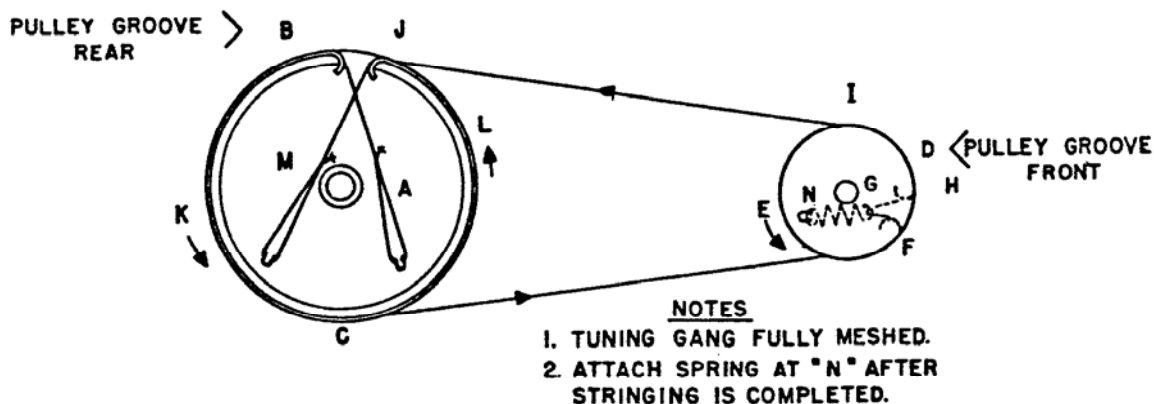

Fig. 5. Main Tuning Gang Drive Stringing Diagram

92C1472-B

ALIGNMENT

- Use an amplitude modulated generator covering 455 KC to 30 MC. Use a modulated output for every step except Step 2.
- Connect output meter across speaker voice coil.
- Use a non-metallic alignment tool.
- Set the AM/CW switch at AM, (except for BFO adjustment), SPEAKER/PHONES switch at SPEAKER, VOLUME control at maximum. RECEIVE/STANDBY switch at RECEIVE and the BAND SPREAD control at 0.
- See Figs. 7 and 8 for location of alignment adjustments.

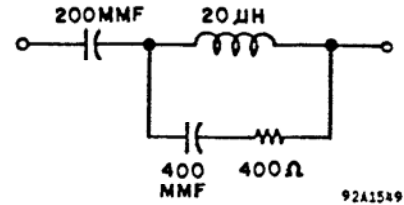

Fig. 6. RTMA Dummy Antenna

Step	Signal Generator Connections	Generator Frequency	Band Selector Setting	Receiver Dial Setting	Adjust
IF ALIGNMENT					
1	High side thru an .01 mfd. capacitor to stator plates of front section of TUNING gang. Low side to chassis.	455 KC	1	1.0 MC	A, B, C and D for maximum output. Keep reducing gen. output so that the reading on the output meter does not exceed 50 milliwatts.
BFO ADJUSTMENT					
*2	Same as Step 1.	455 KC (No Mod.)	1	1.0 MC	Set the AM/CW switch at CW. (Reset the switch at AM when Step 2 is completed.) For correct BFO operation, vary the coupling between lead E and pins 4 and 8 of the 12SG7 (V-2) for a maximum beat note. Pushing lead E toward pin 4 increases the strength of the beat.
RF ALIGNMENT					
3	High side thru RTMA dummy antenna (Fig. 6) to terminal A1 on back of chassis. Low side to chassis. Connect jumper between A2 and G.	30 MC	4	30 MC	F and G for maximum output as in Step 1.
4	Same as Step 3.	14 MC	3	14 MC	H and J for maximum output as in Step 1.
5	Same as Step 3.	5 MC	2	5 MC	K and L for maximum output as in Step 1.
6	Same as Step 3.	1500 KC	1	1.5 MC	M and N for maximum output as in Step 1.
		600 KC	1	.6 MC	P for maximum output as in Step 1.

* Step 2 is usually unnecessary. Adjustment should be made ONLY if a weak beat note is obtained on strong CW signals indicating lack of coupling between wire lead E and pins 4 and 8 of the 12SG7.

SERVICE OR OPERATING QUESTIONS -For any further information regarding operation or servicing of your receiver, contact your Hallicrafters dealer. The Hallicrafters Co. maintains an extensive system of authorized service centers where any required service will be performed promptly and efficiently at a nominal charge. All Hallicrafters Authorized Service Centers display the sign shown at the right. For the location of the one nearest you, consult your dealer or telephone directory.



The Hallicrafters Co. reserves the privilege of making revisions in current production of equipment and assumes no obligation to incorporate these revisions in earlier models.

92X1401-C

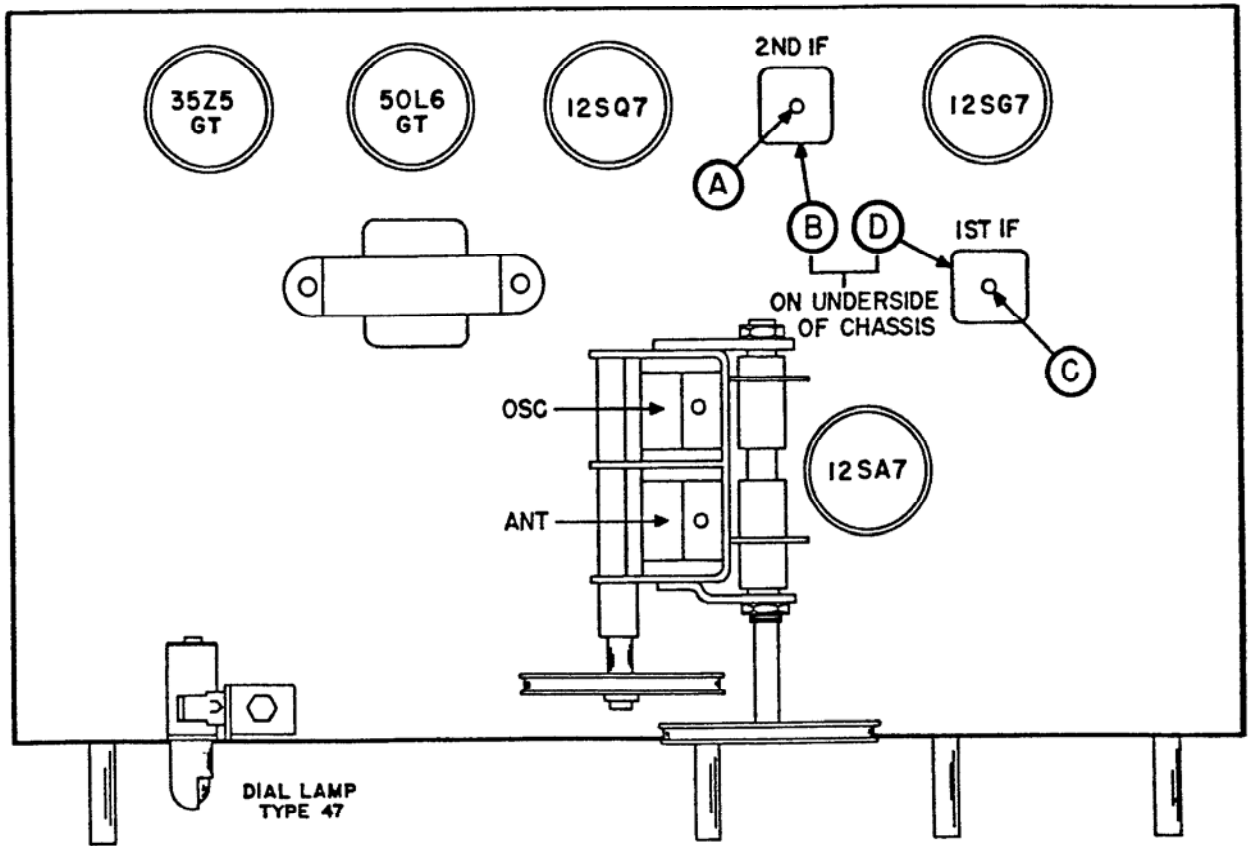

92C1777-A

Fig. 7. Top View of Chassis Showing Location of Alignment Adjustments, Tubes and Dial Lamp

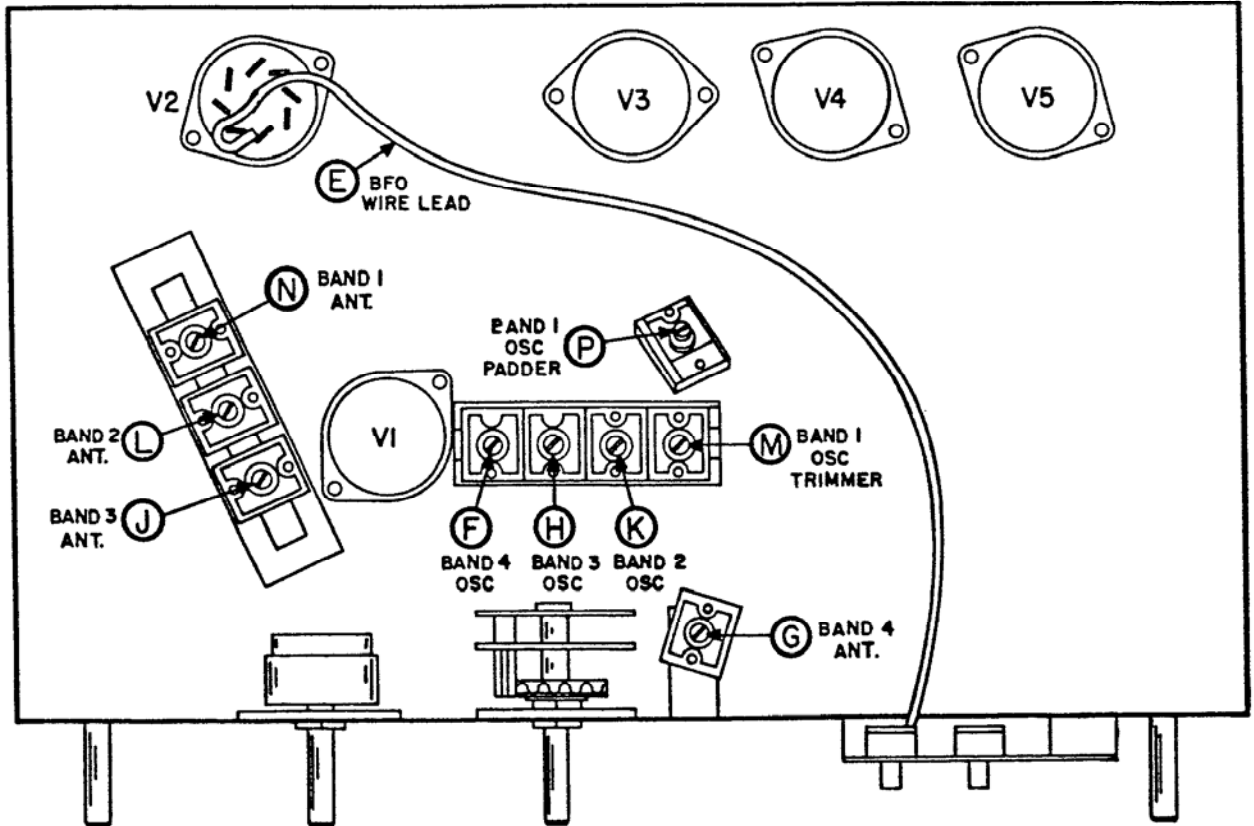

92C2349

Fig. 8. Bottom View of Chassis Showing Location of Alignment Adjustments and Tubes.

SERVICE PARTS LIST

Schematic Symbol	Description	Hallicrafters Part Number	Schematic Symbol	Description	Hallicrafters Part Number
CAPACITORS			SWITCHES		
C-1-2-3	Trimmer assembly, 3 section; 2-25 mmfd., 2-25 mmfd., 4-40 mmfd.	44B129	S-1A-B-C-D	Switch, rotary wafer; Band Selector	60C393
C-4	20-120 mmfd., mica trimmer . .	44A424	S-2,5	Switch, spdt slide; Speaker-Phones and AM-CW	60A477
C-5	2700 mmfd, 5%, 500 V.; mica . .	47X30B272J	S-3	Switch, on-off; part of Volume control R-9	-----
C-6A-B-C-D	Tuning capacitor, 2 section; includes drive pulleys	48-269	S-4	Switch, spst slide; Receive-Standby	60A476
C-7,12,16	220 mmfd. 10%, 500V.; mica . .	47X20B221K	SOCKETS AND CONNECTORS		
C-8,15	0.02 mfd. 600V., tubular paper .	46AY203J	TS-1	Terminal strip, antenna	88A671
C-9	0.05 mfd. 200V., tubular paper .	46AU503J	TS-2	Twin jack strip, Phones	88A071
C-10	0.003 mfd. 600V., tubular paper .	46AZ302F		Socket, dial lamp; with leads . .	86A122
C-11A-B-C-D	Printed circuit capacitor plate, .005 mfd., 220 mmfd., 220 . mmfd., .002 mfd.	46A151		Socket, octal tube	6A250
C-13	0.01 mfd. 600 V., tubular paper .	46AZ103J	TUBES AND DIAL LAMP		
C-14A-B-C-D	Filter capacitor, 4 section; 20 mfd. 25V, 60-40-40 mfd, 150V.	45B091	V-1	12SA7: converter	90X12SA7
C-17	425-625 mmfd., mica padder . . .	44A349	V-2	12SG7: IF amplifier and BFO . .	90X12SG7
C-18	2200 mmfd, 5%, 500V.; mica . .	47X30B222J	V-3	12SQ7: detector and audio amplifier	90X12SQ7
C-19	3000 mmfd. 5%, 500V.; mica . .	47X30B302J	V-4	50L6GT: audio output	90X50L6GT
C-20-21-22-23	Trimmer assembly, 4 section; 6.5-70 mmfd., 3.5-30 mmfd., 2.5-18 mmfd., 3.5-30 mmfd. . .	44B159	V-5	35Z5GT: rectifier	90X35Z5GT
C-24	0.05 mfd. 600V., tubular paper .	46AY503J	LM-1	Lamp, dial; type 47	39A004
C-25,26,31	0.005 mfd. 450V., ceramic disc .	47A168	MISCELLANEOUS		
C-27	0.02 mfd. 600V., molded tubular paper	46BR203L6		Cabinet	66C1070
C-28	0.01 mfd. 450V., ceramic disc .	47A224		Cabinet back	32C500
C-32	0.01 mfd. 200V., tubular paper .	46AU103J		Cabinet bottom cover	32C501
* RESISTORS				Channel, rubber; for escutcheon glass	16A212
R-1	10,000 ohms	23X20X103K		Clip, dial mtg.	76A646
R-2,5	2.2 megohms	23X20X225K		Clip, escutcheon glass mtg. . . .	76A645
R-3	22,000 ohms	23X20X223K		Clip, IF mtg.	76A385
R-4	270 ohms	23X20X271K		Clip, mtg.; for coil L-2	76A326
R-6	330 ohms	23X20X331K		Clip, mtg.; for dial lamp socket.	76A660
R-7	47,000 ohms	23X20X473K		C-washer	4A139
R-8,12,21,22	470,000 ohms	23X20X474K		Dial background, paper	32B679
R-9	2 megohms, variable; Volume control (includes on-off switch S-3)	25B896		Dial cord (specify length)	38A026
R-10	10 megohms	23X20X106K		Dial scale	22E426
R-11	220,000 ohms	23X20X224K		Escutcheon, front panel	7C587
R-13	100 ohms	23X20X101K		Glass, escutcheon	22B319
R-14,15,17	15 ohms	23X20X150K		Grommet, rubber; gang mtg. . . .	16A015
R-16,18,24	22 ohms	23X20X220K		Grommet, rubber; switch bracket mtg.	16A125
R-19	220 ohms, 1 watt	23X30X221K		Knob, Band Selector	15B323
R-20	1000 ohms	23X20X102K		Knob, Bandsread, Off-Volume, and Tuning	15B322
R-23	470 ohms	23X20X471K	PL-1	Line cord and plug	87A078
*All resistors are 1/2 watt, 10%, carbon type unless otherwise specified.				Line cord lock male section	76A397-1
COILS AND TRANSFORMERS				Line cord lock female section	76A397-2
**L-1, C-1-2-3	Coil and trimmer assembly, antenna; bands 1,2, and 3	51C821		Mounting foot, rubber	16A244
L-2	Coil, antenna; band 4	51B1015		Pointer, dial bandsread tuning	82A198
**L-3, C-20-21-22-23	Coil and trimmer assembly, oscillator; all bands	51C822		main tuning	82A251
L-4	Choke, RF; 540 uh	53A107		Pulley, 1-13/32" od	28A090
T-1	Transformer, 1st IF	50C531		Pulley, 2.625" od	28A091
T-2	Transformer, 2nd IF	50C532		Retaining ring, "E" type (for bandsread idler pulleys)	76A776
T-3	Transformer, audio output	55A127		Retaining ring, "E" type (for tuning and bandsread shafts) .	76A811
** The trimmer capacitor assemblies are also available separately. See "Capacitors".			LS-1	Shield, dial lamp	8A1249
				Speaker, 5-inch PM; 3.2 ohm voice coil	85C030
				Spring, dial drive; 17/32"	75A012
				Spring, dial drive; 3/8"	75A173

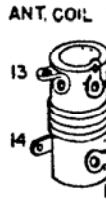
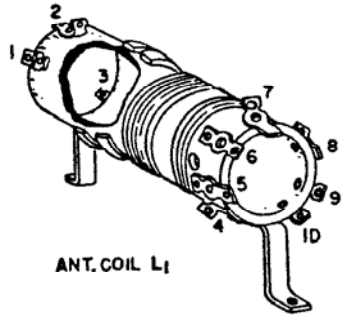
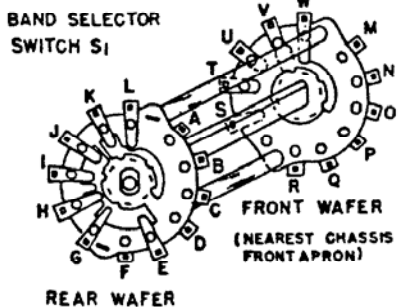
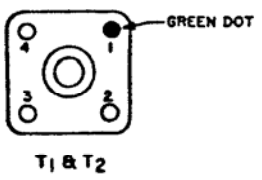
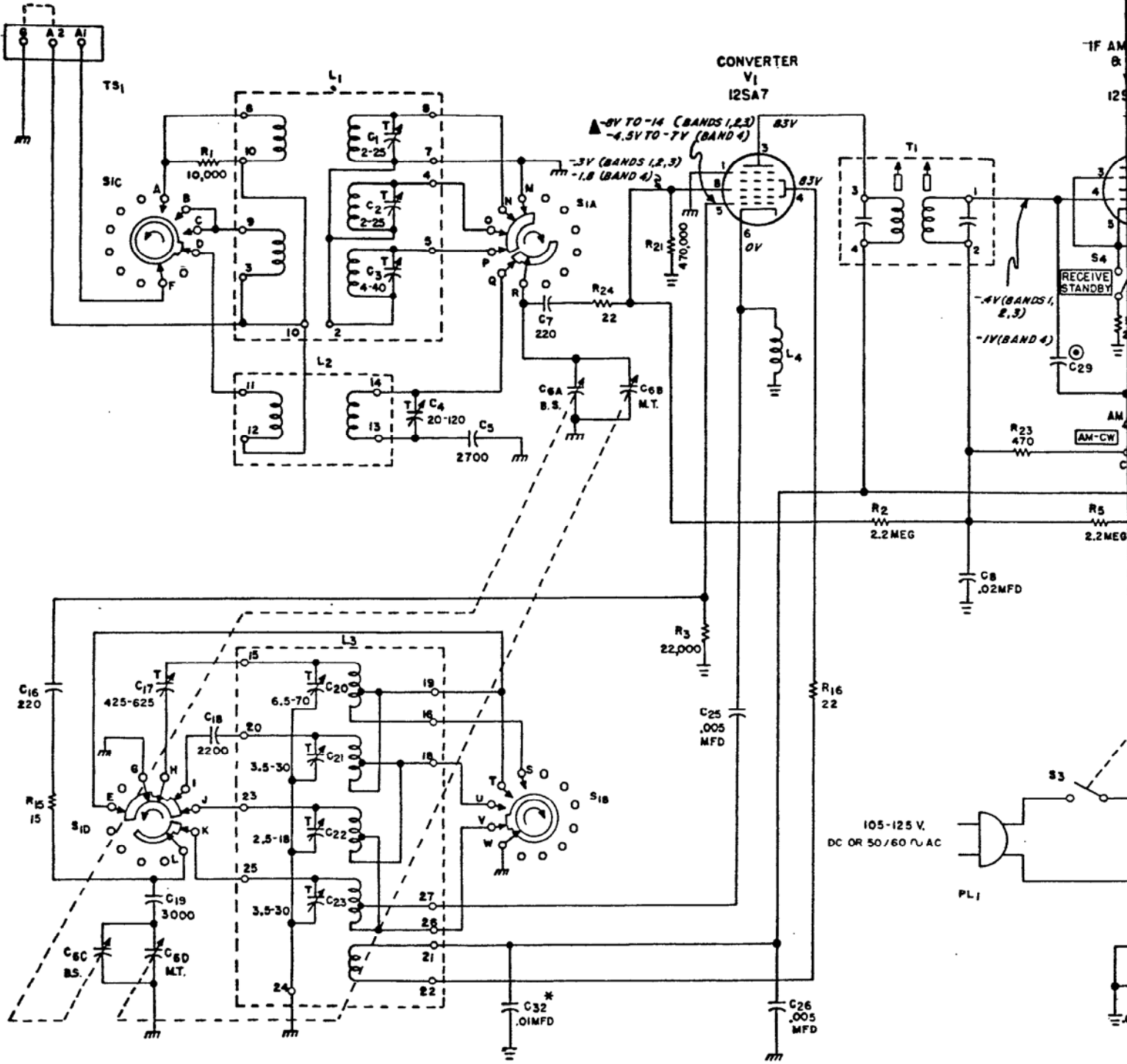

NOTE: VALUES & TOLERANCES SHOWN ARE N
IT IS RECOMMENDED THAT THE VALUE
TO THE NOMINAL VALUE OF THE PART

